



418 •

Xdream small case

Functionality "to the X degree"

The X-dream small case offers maximum functionality. The solid aluminium extrusion case body forms the extremely stable basis of the case.



Sample configuration

Integrated dovetail guides allow the adapter rails to be moved into different positions, which allows standard-format cards or different size electronics to be installed. This patented design creates space that has never before been available in small cases. When used with seals and front panels (see accessories), the stylish frame provides maximum protection against exterior influences (up to IP 66 degree of protection). Base feet or customized mounting equipment can be fit into the practical mounting grooves on the underside of the case.

The X-dream small case series can also be fit or retrofitted with a prop-up and carrying handle.

Xdream small case

- all standard-size cards (100, 120, 160, 190 to 233.35mm) can be installed in one case
- adapter rails allow you to customize your installation
- patented design
- up to IP 66 degree of protection
- high stability
- adjustable depths
- stackable
- integrated mounting grooves
- functional accessories
- prop-up and carrying handle optional



Specifications

Application:

Basic case for electronics and other standard-sized cards. Adapter rails that can be positioned inside the case allow you to customize your card installation. Cards with different widths can be placed in different positions within the case.

Construction:

solid aluminium extrusion that is enclosed by a plastic frame on the front and rear

Finish:

RAL 7035 light grey frame, black

Degree of protection: IP 66*

Delivery: not assembled

Standard case for 160/120mm card depths

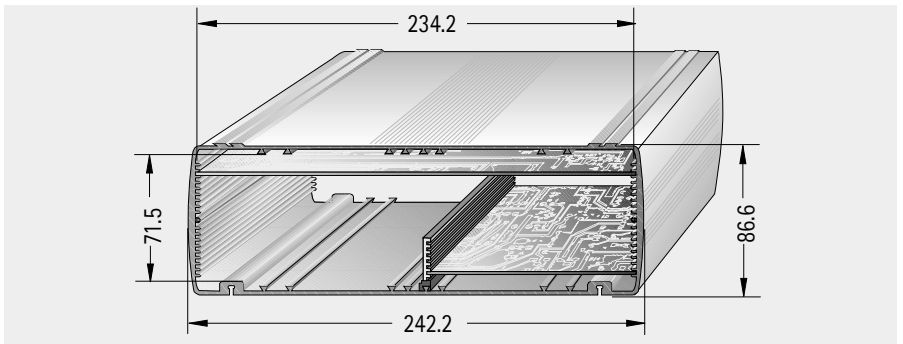
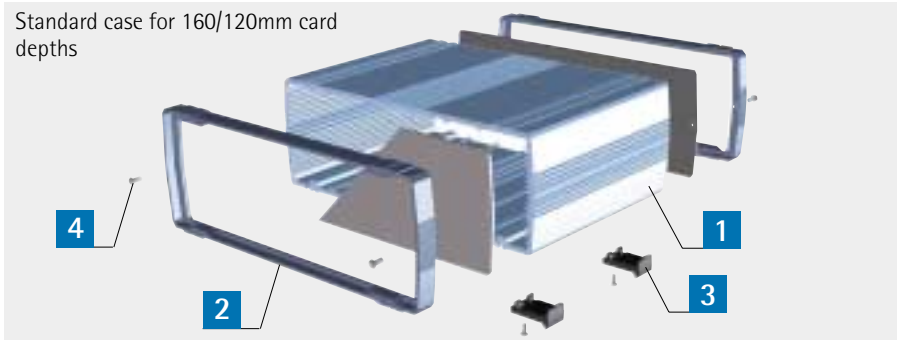

Included in delivery

Item	Pc.	Description
1	1	Aluminium extrusion
2	2	Plastic frame
3	4	Stacking feet
4		Assembly material

Order information

Description	for card depths d mm	Part no.
Small case, D=180mm	160	41-8001-60
Small case, D=180mm with handle	160	41-8001-65
Small case, D=240mm	220	41-8002-20
Small case, D=240mm with handle	220	41-8002-25

(*with solid rear and front panels and frame seals, without handle)

Accessories

Front panel/rear panel



Material: aluminium, 2.5mm

Finish: anodized exterior side, transparent chromated interior side

Part no.
41-8004-00

Frame seal



• self-adhesive, for adhering to front or rear panel

Part no.
41-8006-02

Adapter rail

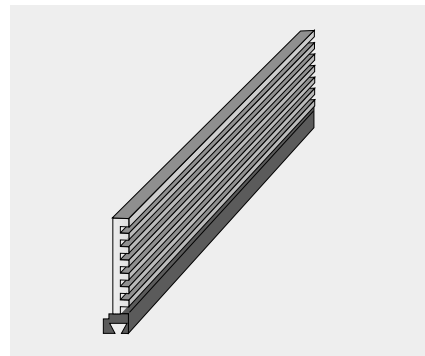

- fits in the case's dovetail guides
- with special sliding surface

Part no. for card depth d = 160mm
41-8003-16

Part no. for card depth d = 220mm
41-8003-22

Prop-up and carrying handle



- for retrofitting
- incl. assembly material

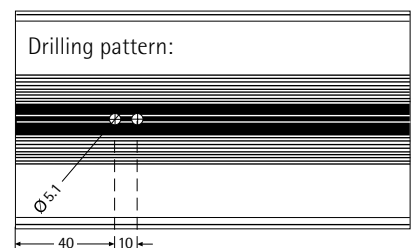

Part no.
61-5060-03